

*Intrinsically safe batching controller*  
**Batching Master 210i**



**Installation Guide**

BVS 04 ATEX E 172

Revision 14



IBS BatchControl GmbH  
Im Sträßchen 2-4  
53925 Kall  
Germany

Tel.: ++49 2441 9199 801  
Mail: [sales@ibs-batchcontrol.de](mailto:sales@ibs-batchcontrol.de)  
Internet: [www.ibs-batchcontrol.com](http://www.ibs-batchcontrol.com)

---

## Safety information



The Batching Master must only be installed by process electronics engineers or qualified electricians who are authorised by the plant operator to carry out these tasks.

The instrument may only be operated by personnel who are authorised and trained by the plant operator.

The Batching Master must only be connected as specified in the electrical data. The upper part of the housing must not be opened, otherwise maintenance of the electrical data is not ensured and the guarantee becomes null and void.

## Validity of Installation and Operating Instructions

- These Installation and Operating Instructions apply to all Batching Master 210i models.
- Your IBS agent will be able to give you information about any improvements or modifications.
- The manufacturer is not responsible for damage caused by incorrect or unauthorised use. Conversions and changes to the instrument must not be made, otherwise the certification and guarantee become invalid.

## Operating safety

- The instruments are manufactured in our ISO 9001 / ATEX certified factory. They comply with the requirements laid down in this standard.
- The Batching Master 210i satisfies the requirements of protection class IP65.
- Danger may occur if the instrument is used incorrectly or in an unauthorised manner. All the information in this manual must be rigorously observed.

## Technical Developments

The manufacturer reserves the right to modify technical data without notice.

## Repairs, dangerous chemicals

Only the IBS BatchControl GmbH is allowed to repair the instruments because the intrinsically safe is at risk. Instruments sent to IBS BatchControl GmbH for repair must always be accompanied by a note describing the fault.



## Warning!

The following procedures must be carried out before an instrument is sent in for repair:

- Remove all residues and deposits that may be present. Pay special attention to the gasket grooves and crevices where residue may collect.
- If materials injurious to health are not completely removed to the highest levels of safety, we cannot accept an instrument for repair.
- Costs of disposal of materials or of injury to personnel (acid burns, etc.) arising because of defective cleaning of the equipment will be charged to the owner of the equipment.

---

## Contents

1	System Description.....	4
1.1	Type Codes.....	4
1.2	Areas of Application.....	5
1.3	Block diagram.....	6
2	Fitting and Installation.....	7
2.1	Fitting the Batching Master 210 i.....	7
2.2	Protection class IP20.....	8
2.3	Temperature range.....	8
2.4	Cable gland and PE.....	8
2.5	Terminal assignment.....	9
2.5.1	Power supply 1.....	9
2.5.2	Power supply 2.....	10
2.5.3	Pulse inputs.....	11
2.5.4	Analogue inputs.....	12
2.5.5	Analogue output.....	13
2.5.6	Digital inputs.....	14
2.5.7	Digital outputs.....	15
2.5.8	Digital input for an additional stop contact.....	16
2.5.9	TTY interface.....	17
2.5.10	Potential equalisation.....	17
2.5.11	Programming enable.....	17
3	Operating and display elements.....	18
3.1	Display.....	18
3.2	Light emitting diodes (LEDs).....	18
3.3	Keyboard.....	18
4	Operation.....	19
4.1	Switching on the Batching Masters.....	19
4.2	Batching with the Batching Master.....	19
4.3	Programming.....	20
5	Terminal assignment.....	21

# 1 System Description

The microprocessor-controlled *Batching Master 210i* is a simple to use multi-function batcher used for the recording and controlling of flow quantities in batching and filling processes in hazardous production areas.

## 1.1 Type Codes

The following types can be supplied:

Batching Master 210i	
Batching Master 210i – SB	Display with back-light
Batching Master 210i – LP	Power supply with two low power supply units

Designation according to Directive 2014/34/EU:

**CE 0158**  **II 2 G**

Designation Ex class:

Ex ib IIC T4

or:

Ex ib IIC T4 Gb

## 1.2 Areas of Application

The units are explosion protected in accordance with EN 60079-0 and EN 60079-11. They can be operated in hazardous areas in zone 1, group IIC, temperature class T4 up to a maximum ambient temperature of 60°C. All incoming and outgoing circuits including the power supply are in accordance with Ex class “intrinsically safe”, category “ib”.

- **The maximum permissible ambient temperature is +60 °C.**
- **The minimum permissible ambient temperature is -20 °C.**

The Batching Master controls batching and terminates this when the preselected quantity is reached. An actuator (4-20 mA) and several contacts are controlled depending on the batching. Up to four control signals can be fed to the Batching Master. A controller is available to control the flow rate or another physical quantity (option).

There is a choice of current (4-20 mA) or contact input. The contact input permits the connection of passive contacts or optical couplers. Selection of the input option is carried out via the software.

The input can be linearised by the software.

The Batching Master can be easily set to the different measuring ranges.

The (active) digital inputs can be assigned various functions (e.g. preselection, start, stop, etc.).

The (passive) digital outputs can be programmed to provide status signalling.

The Batching Master can be configured and controlled via a serial interface (MODBUS). The *IPC 300i* is available for this purpose.

Access to the various program levels can be protected by a numerical code.

The *Batching Master 210i* is supplied in a panel mount housing (IP20) with external dimensions of 144mm x 144mm.

1.3 Block diagram

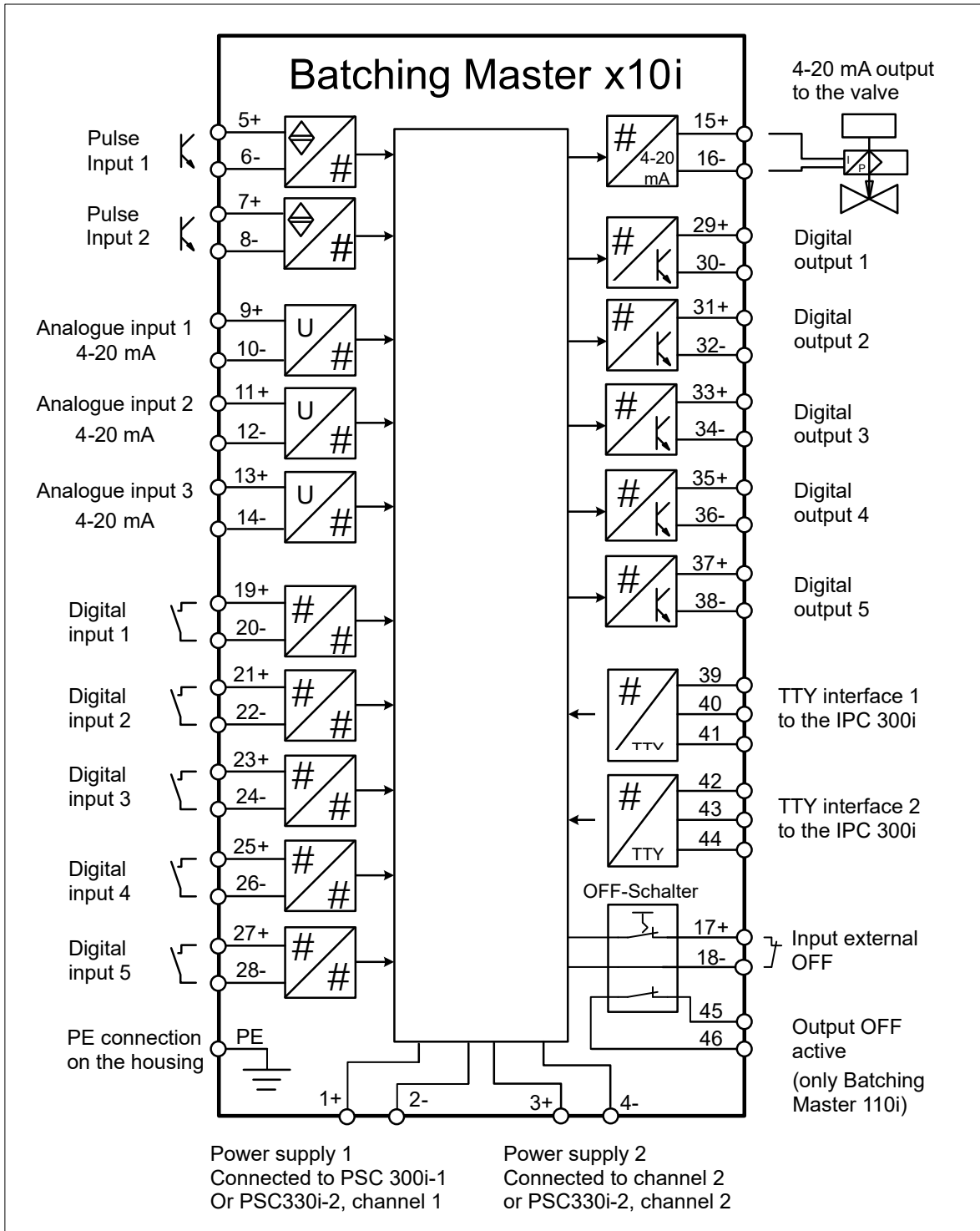

## 2 Fitting and Installation

This information in this section is important and must be observed during fitting and installation.

### 2.1 Fitting the Batching Master 210 i

The *Batching Master 210 i* has external dimensions of 144 mm x 144 mm. You need a cut off in the panel mount with the dimensions of 138 +1,0 mm x 138 +1,0 mm (DIN43700). The depth is 100mm.

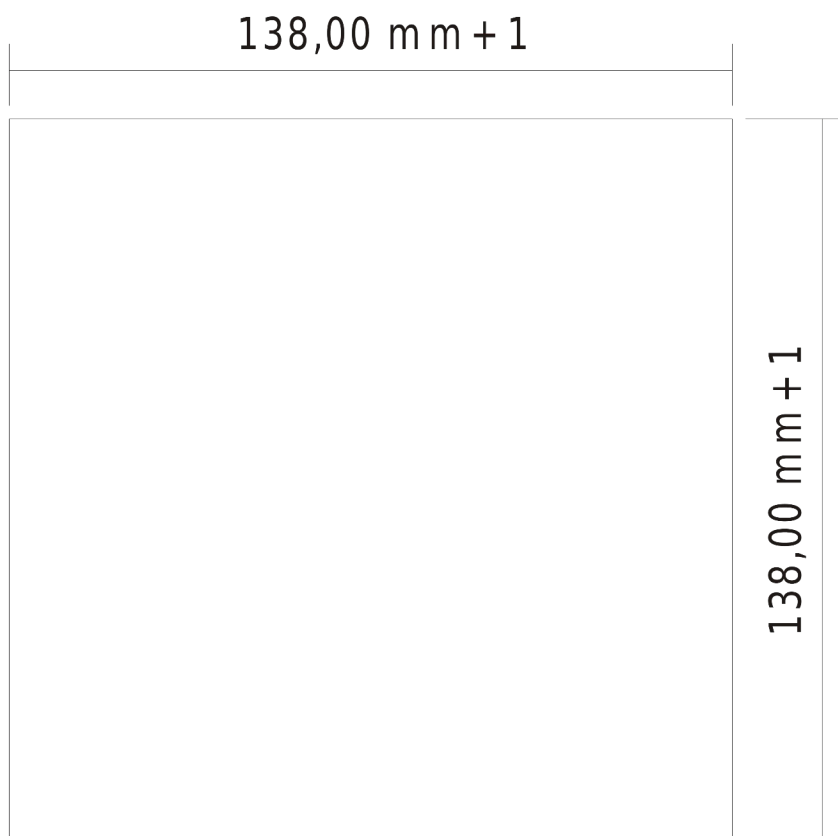

Release the two mounting profile screws. Shift the mounting profiles backwards from the panel mounting housing. Move the *Batching Master 210 i* from the front side through the cut off in the panel mount.

Keep the unit horizontal and put the mounting profiles into the specified notches they are taken away before.

Tighten the mounting profile screws evenly with a screw driver

## **2.2 Protection class IP20**

The *Batching Master 210 i* conforms to protection class IP20.

## **2.3 Temperature range**

The *Batching Master 210i* can be operated in the range  $-20^{\circ}\text{C}$  to  $+60^{\circ}\text{C}$ .

## **2.4 Cable gland and PE**

Only shielded cable may be used. The shield must be connected in the casing or the EMC clamps. The PE must be connected to the PE terminal at the Batching Master housing.

Conformance with the EMC regulations can only be guaranteed if these measures are observed.

## 2.5 Terminal assignment

The technical data in the Certificate of Conformance must be observed at all times. A Batching Master 210i may only be operated with intrinsically safe circuits if the certified maximum values are observed.



### 2.5.1 Power supply 1

The power supply provides power for the electronic, the analogue output and the digital inputs and outputs. The first and second power supply is required for the -LP (Low Power) version.

Terminal 1 (+) Terminal 2 (-)			
An <b>intrinsically safe</b> power supply with the following maximum values can be connected:			
		Version -SB	Warning: Version -LP
Voltage $U_i$	DC 28.5 V	DC 28.5 V	DC 28.5 V
Current $I_i$	190 mA	190 mA	95 mA
Power $P_i$	1.4 W	1.4 W	0.7 W
effective internal inductance $L_i$	negligible		
effective internal capacitance $C_i$	negligible		

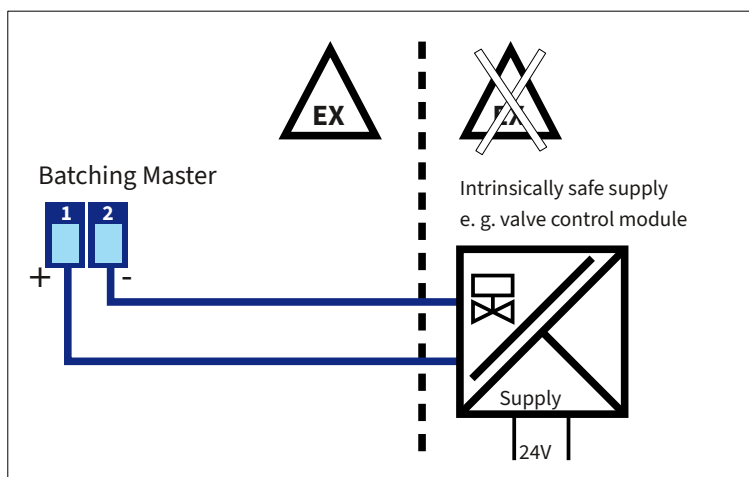

For Ex ib IIC operation, you will need an intrinsically safe supply voltage (e. g. PSC 300i or IPC 300i).

### 2.5.2 Power supply 2

This power supply is only used for back-light (-SB) or low power version (-LP).

Terminal 3 (+) Terminal 4 (-)		
An <b>intrinsically safe</b> power supply with the following maximum values can be connected:		
	Version -SB	Warning: Version -LP
Voltage $U_i$	DC 28.5 V	DC 28.5 V
Current $I_i$	100 mA	95 mA
Power $P_i$	1.2 W	0.7 W
effective internal inductance $L_i$	negligible	
effective internal capacitance $C_i$	24 nF	

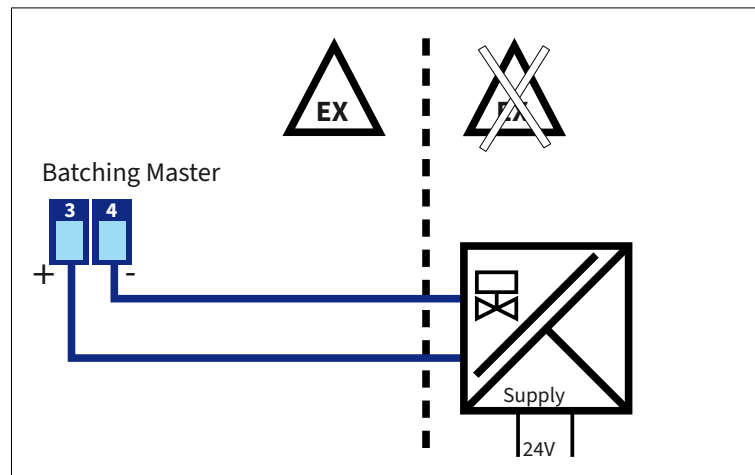

For Ex ib IIC operation, you will need an intrinsically safe supply voltage (e. g. PSC 3x0i or IPC 3x0i).

### 2.5.3 Pulse inputs

The Batching Master has connections for 2 pulse inputs for connection passive pulse outputs from flow sensors or isolation cards. The second pulse input is needed for evaluation purposes when using certified instruments. Namur contacts or passive electrically isolated contacts (optocoupler, relay contact) may be connected.

Pulse input 1: Terminal 5 (+) Terminal 6 (-)	
Pulse input 2: Terminal 7 (+) Terminal 8 (-)	
The following values may occur for each circuit:	
Voltage $U_o$	DC 6 V
Current $I_o$	4 mA
max. external inductance $L_o$	5 mH
max. external capacitance $C_o$	10 $\mu$ F
effective internal inductance $L_i$	negligible
effective internal capacitance $C_i$	24 nF

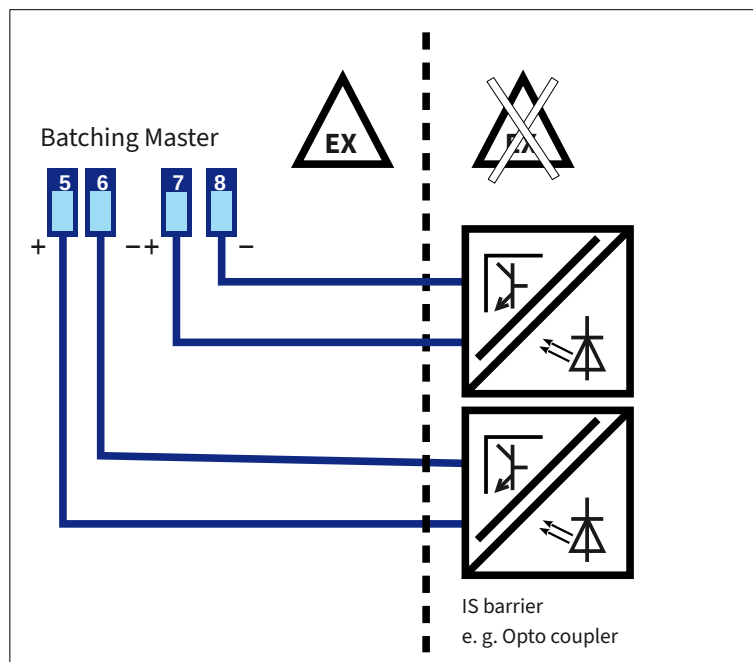

The pulse input supplies a constant current of approx. 3 mA. The maximum voltage that can be measured is approximately 5.6 V. Please note that terminals 6 and 8 must not be connected to ground and not to the same potential.

### 2.5.4 Analogue inputs

The Batching Master has three analogue inputs (4-20 mA).

The analogue inputs are not voltage-free, i.e. the minus is at instrument ground potential. The equipment connected must be able to drive a load of approx. 100Ω.

Current input 1: Terminal 9 (+) Terminal 10 (-)	
Current input 2: Terminal 11 (+) Terminal 12 (-)	
Current input 3: Terminal 13 (+) Terminal 14 (-)	
Intrinsically safe supply circuits with the following maximum values can be connected to each circuit:	
Voltage $U_i$	DC 30 V
Current $I_i$	170 mA
Power $P_i$	0.75 W
effective internal inductance $L_i$	negligible
effective internal capacitance $C_i$	24 nF
The values $U_0$ , $I_0$ and $P_0$ are negligible.	

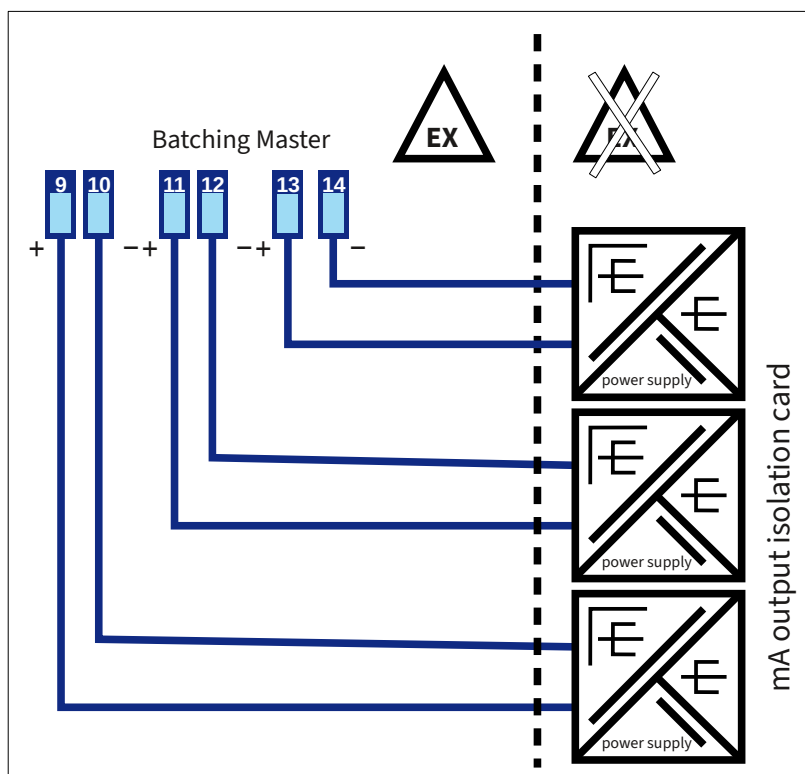

### 2.5.5 Analogue output

The Batching Master has an analogue output (4-20 mA) for controlling a valve.

The analogue output is not electrically isolated. The minus is at ground potential. The maximum load that can be connected depends on the valve control module that supplies the Batching Master. A load of up to 550Ω can be driven by the PSC 300i.

Analogue output: Terminal 15 (+) Terminal 16 (GND)	
The following values may occur:	
Voltage $U_o$	DC 18 V
Current $I_o$	95 mA
Power $P_o$	690 mW
max. external inductance $L_o$	5 mH
max. external capacitance $C_o$	280 nF
effective internal inductance $L_i$	negligible
effective internal capacitance $C_i$	24 nF

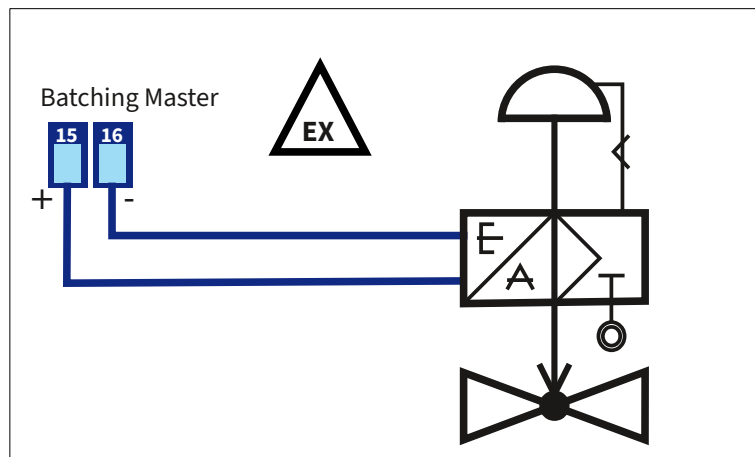

The current output is switched off when the emergency stop switch is operated.

### 2.5.6 Digital inputs

The Batching Master has four digital inputs. The digital inputs can be assigned a wide range of functions via the software.

The digital inputs are active (approx. 100µA/5V). Passive switches or optical couplers can be connected.

Digital input 1: Terminal 19 (+) Terminal 20 (GND)	
Digital input 2: Terminal 21 (+) Terminal 22 (GND)	
Digital input 3: Terminal 23 (+) Terminal 24 (GND)	
Digital input 4: Terminal 25 (+) Terminal 26 (GND)	
Digital input 5: Terminal 27 (+) Terminal 28 (GND)	
The following values may occur for each circuit:	
Voltage $U_o$	DC 6 V
Current $I_o$	1 mA
max. external inductance $L_o$	1000 mH
max. external capacitance $C_o$	40 µF
effective internal inductance $L_i$	negligible
effective internal capacitance $C_i$	negligible
<b>Intrinsically safe</b> supply circuits with the following maximum values can be connected to each circuit:	
Voltage $U_i$	DC 36 V
Current $I_i$	100 mA
Power $P_i$	1 W

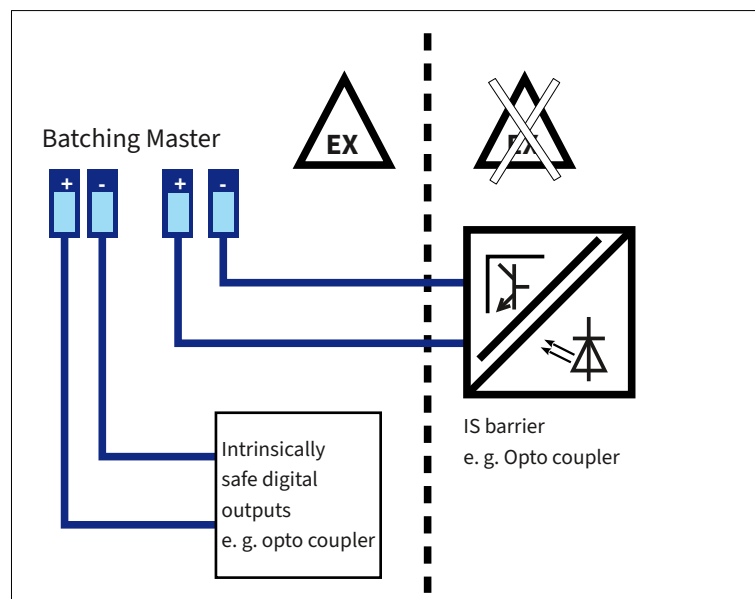

### 2.5.7 Digital outputs

The Batching Master has five digital outputs. The digital outputs can be assigned a wide range of functions via the software. Control outputs 1 to 3 are switched off when the emergency stop switch is operated. These contacts then open.

The control outputs are electrically isolated and passive. Please note the potential direction of the outputs.

Digital output 1: Terminal 29 (+) Terminal 30 (-)	
Digital output 2: Terminal 31 (+) Terminal 32 (-)	
Digital output 3: Terminal 33 (+) Terminal 34 (-)	
Digital output 4: Terminal 35 (+) Terminal 36 (-)	
Digital output 5: Terminal 37 (+) Terminal 38 (-)	
The following values may occur for each circuit:	
Voltage $U_o$	DC 6 V
Current $I_o$	2 mA
effective internal inductance $L_i$	negligible
effective internal capacitance $C_i$	negligible
<b>Intrinsically safe</b> supply circuits with the following maximum values can be connected to each circuit:	
Voltage $U_i$	DC 36 V
Current $I_i$	150 mA
Power $P_i$	1.35 W

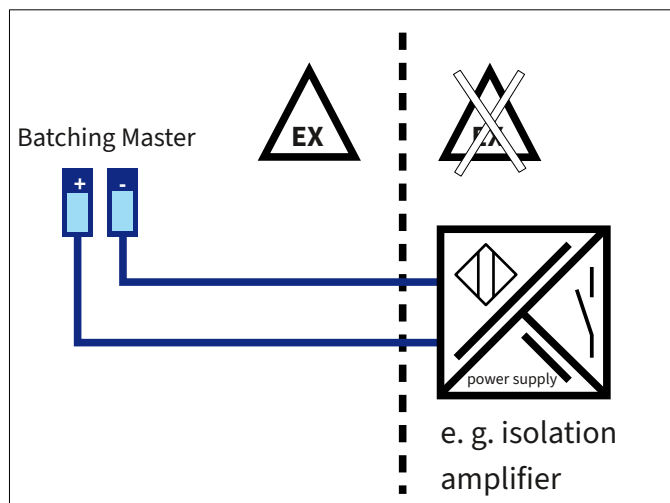

### 2.5.8 Digital input for an additional stop contact

An external passive stop switch can be connected to these terminals. If an external stop switch is not connected, these terminals must be linked. When the switch is operated, a hardware action switches off digital outputs 1 to 3 and the current output, i.e. the current is less than 4 mA and digital outputs 1 to 3 are open. The OFF switch at the front has the same function.

Active emergency stop: Terminal 17 (+) Terminal 18 (GND)	
The following values may occur:	
Voltage $U_o$	DC 6 V
Current $I_o$	18 mA
max. external inductance $L_o$	200 mH
max. external capacitance $C_o$	40 $\mu$ F

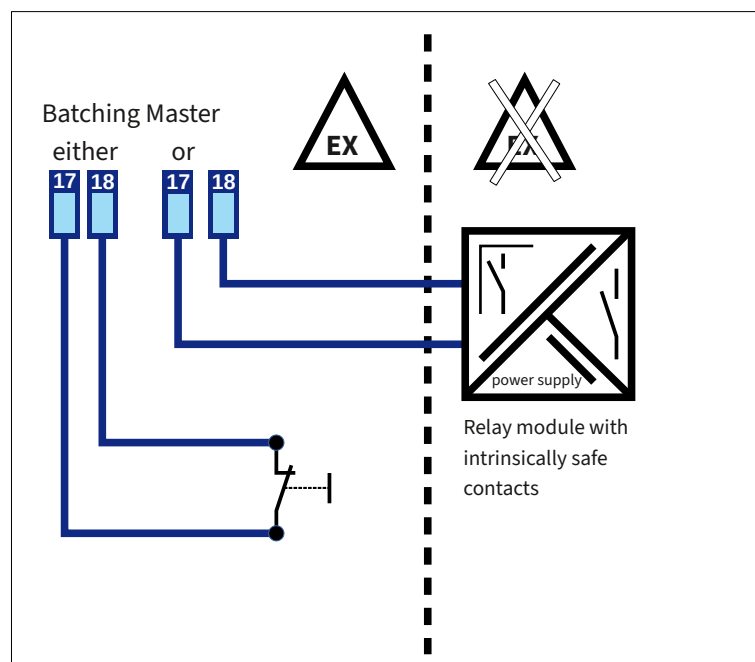

### 2.5.9 TTY interface

A higher level system can be connected to the intrinsically safe interface using an IPC 300i.

TTY interface 1: Terminal 39 (RxD) Terminal 40 (GND) Terminal 41 (TxD)	
TTY interface 2: Terminal 42 (RxD) Terminal 43 (GND) Terminal 44 (TxD)	
The following values may occur for each circuit:	
Voltage $U_o$	DC 6 V
Current $I_o$	4 mA
effective internal inductance $L_i$	negligible
effective internal capacitance $C_i$	2.4 nF
Intrinsically safe supply circuits with the following maximum values can be connected to each circuit:	
Voltage $U_i$	DC 14 V
Current $I_i$	60 mA
Power $P_i$	0.52 W
effective internal inductance $L_i$	negligible
effective internal capacitance $C_i$	2.4 nF

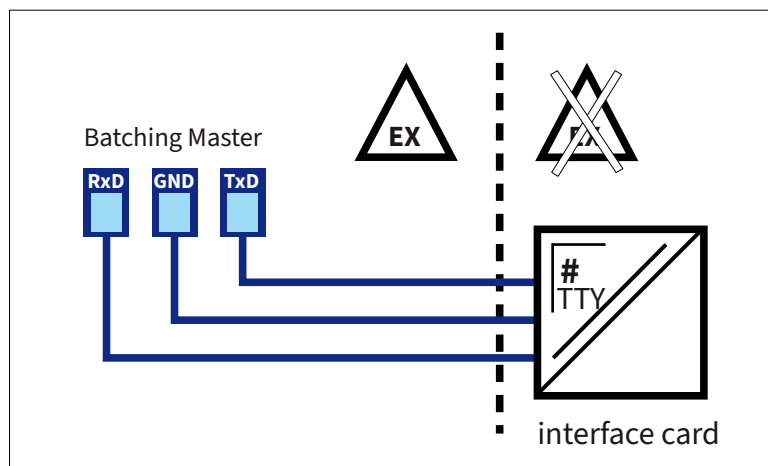

### 2.5.10 Potential equalisation

The PE must be connected to the PE terminal on the side of the housing.

### 2.5.11 Programming enable

For certified custody transfer instruments, there is a small switch near the connection terminals. In the case of certified instruments, the switch is sealed by the Weights and Measures Office and cannot be operated. In such cases it will not be possible to amend any of the certification data.

## 3 Operating and display elements

### 3.1 Display



The LCD display has two lines of 16 characters each. The character height is approx. 10 mm. An LCD back-light is available in version –SB.

The upper LCD indicates the preselected quantity. The lower LCD indicates the current quantity batched. The display can be changed to flow, totaliser or flow controller (only if this is active) using the [#] key. The contrast can be adjusted by pressing the [◀] and [▶] keys.

### 3.2 Light emitting diodes (LEDs)

The LEDs in function keys F1 to F3 can indicate various conditions. The RC LED indicates that data can be read and written by the interface.

### 3.3 Keyboard

The Batching Master has 24 short-stroke keys. In addition, there is an emergency stop switch in the housing.

In these Operating Instructions, keys are shown in square brackets. For instance, if the number 15 is to be entered, this is shown as [15]. The Set key is shown as [Set].

## 4 Operation

The upper line of the display indicates the preset quantity. In programming mode, the function to be executed is displayed.

The lower line indicates the quantity batched. In programming mode, the value of the function or setting is shown.

You can switch the lower display to flow indication with the [#] key. You can switch to totaliser by pressing the key again. The totaliser indication is only possible when batching is not taking place. The display resets itself after about 4 seconds.

If the flow controller is active, the flow setpoint is displayed in the upper display by pressing the [#] key at the same time as the flow is being indicated in the lower display.

If a limiting controller is switched on, the lower display will show the controlled variable rather than the flow when the [RC] key is pressed. The upper display shows the reference variable. The controller display resets itself to the batched quantity after about 4 seconds.

If the lower display indicates flow at the start of batching, it will switch automatically to the batched quantity. The flow can then be displayed again by pressing the [#] key. The display will not automatically revert to batched quantity.

The quantity is always shown with the appropriate unit in each case.

The RC key also contains a red LED to indicate that the remote control interface is on.

Keys 1 to 3 contain additional indicator LEDs. Functions can be assigned to these LEDs.

These LEDs can also be activated via the interface. Keys F1 to F3 can be interrogated via the interface.

### 4.1 Switching on the Batching Masters

The instrument carries out a self-test as soon as it is connected to the power supply. The instrument number and software version are displayed. All data stored in the FRAM (ferro-electric non-volatile RAM, a non-volatile data memory) is then read.

The most recent preselected and batched quantities are displayed. The instrument waits for an input.

### 4.2 Batching with the Batching Master

You must press the [Reset] key before the first batching process. The last preselection is reset.

Enter the preselected quantity using the numeric keys [1 to 9]. A decimal point will be displayed in a fixed position.

The preselection value must be confirmed with [Set]. The last quantity batched is set to 0.

The Batching Master is now ready to start batching.

Press the [Start] key to start batching. The digital shutoff steps switch on, the current output runs up to 20 mA. Active batching is indicated on the display (B appears at the bottom left). You can interrupt the batching with [Stop] or OFF at any time.

Batching interrupted with Stop can be continued immediately with [Start]. If batching is stopped as the result of an OFF, the fault message must first be reset with [Reset]. You can then continue batching with [Start].

A new batching process can be started immediately with [Set] [Start] if the preselected quantity does not need to be changed.

After stopping, batching can be terminated with RESET.

After a supply break down you can take up the batch with [Start] again.

### 4.3 Programming

To enter the programming level, press the Menu key. The Batching Master displays the current software version and the instrument number for a short time.

If a sub-menu is selected, you can access the next level using the  $\blacktriangleright$  key. A code is requested if one has been entered. The code request is by-passed if the programming enable switch is on. For certified instruments, the certification data can only be changed by switching on the programming enable switch (install, calibration and characteristic level).

Programming is only implemented when the "Quit programming" menu level is correctly terminated. The programming level is quit via a selection menu by pressing the  $\blacktriangleleft$  key to exit all levels. The "Save" prompt appears. You can change from "No" to "Yes" using the  $\blacktriangleup$ / $\blacktriangledown$  keys. The setting is then confirmed by pressing the  $\blacktriangleleft$  or Set key. All data are saved. The batch controller is now in batching mode again. Programming cannot take place during batching (except for the controller function).

If the Batching Master detects invalid data in FRAM, a fault message is issued. A COLD-START can be initiated by pressing the RC key when switching on. A prompt appears asking whether all data is to be deleted (factory) or whether just the settings (basic settings) are to be reset (software options, characteristic and instrument number). The factory reset cannot be accessed by the user.

Further settings are described in the user manual.

## 5 Terminal Assignment

<b>Terminal</b>	<b>Function</b>	<b>Remark</b>	<b>Page</b>
1	Power supply 1 +		9
2	Power supply 1 -		
3	Power supply 2 +	Only for LP- (Low power) or SB- (backlight) versions	9
4	Power supply 2 -	Only for LP- (Low power) or SB- (backlight) versions	
5	Pulse input 1 +		11
6	Pulse input 1 -		
7	Pulse input 2 +		11
8	Pulse input 2 -		
9	4/20 mA analogue input 1+		12
10	4/20 mA analogue input 1-		
11	4/20 mA analogue input 2+		12
12	4/20 mA analogue input 2-		
13	4/20 mA analogue input 3+		12
14	4/20 mA analogue input 3-		
15	4/20 mA analogue output +		13
16	4/20 mA analogue output +		
17	Digital input for an external stop contact +		16
18	Digital input for an external stop contact +		
19	Digital input 1 +		14
20	Digital input 1 -		
21	Digital input 2 +		14
22	Digital input 2 -		
23	Digital input 3 +		14
24	Digital input 3 -		
25	Digital input 4 +		14
26	Digital input 4 -		
27	Digital input 5 +		14
28	Digital input 5 -		

## Terminal Assignment

---

<b>Terminal</b>	<b>Function</b>	<b>Remark</b>	<b>Page</b>
29	Digital output 1 +		15
30	Digital output 1 -		
31	Digital output 2 +		15
32	Digital output 2 -		
33	Digital output 3 +		15
34	Digital output 3 -		
35	Digital output 4 +		15
36	Digital output 4 -		
37	Digital output 5 +		15
38	Digital output 5 -		
39	Interface 1 RxD		17
40	Interface 1 GND		
41	Interface 1 TxD		
42	Interface 2 RxD		17
43	Interface 2 GND		
44	Interface 2 TxD		
45	Digital output „stop pressed“	only for Batching Master 110i	16
46	Digital output „stop pressed“	only for Batching Master 110i	